

# DC EXHIBIT E

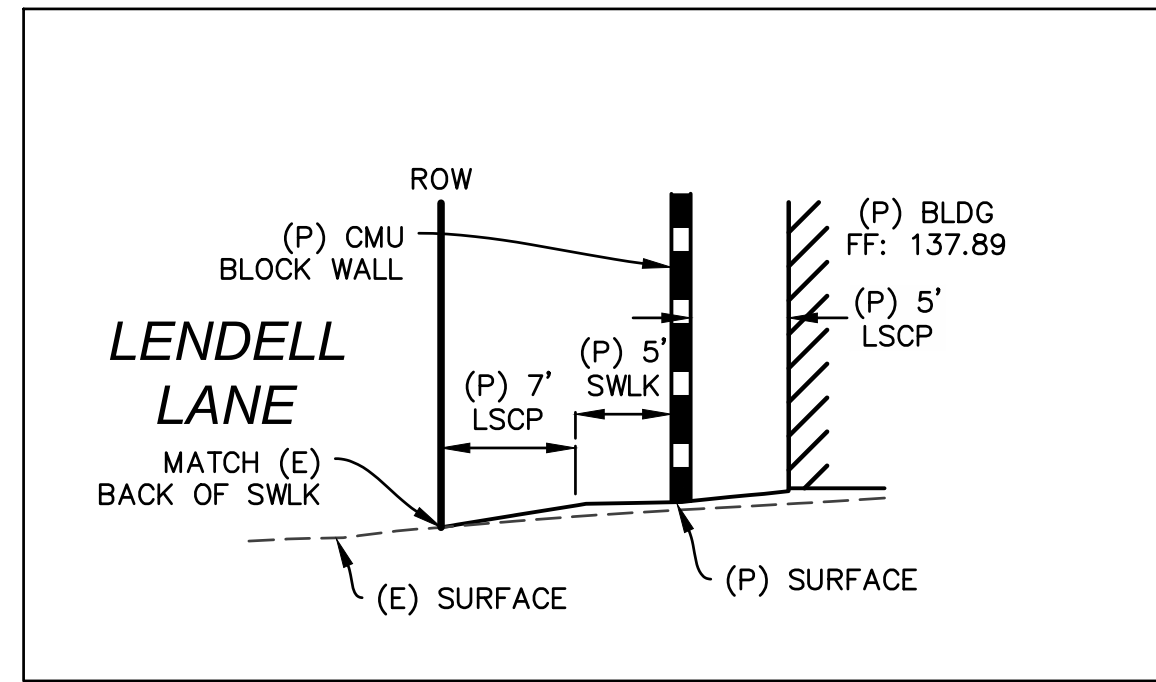

**SECTION A**  
HORIZONTAL SCALE: 1" = 10'  
VERTICAL SCALE: 1" = 5'

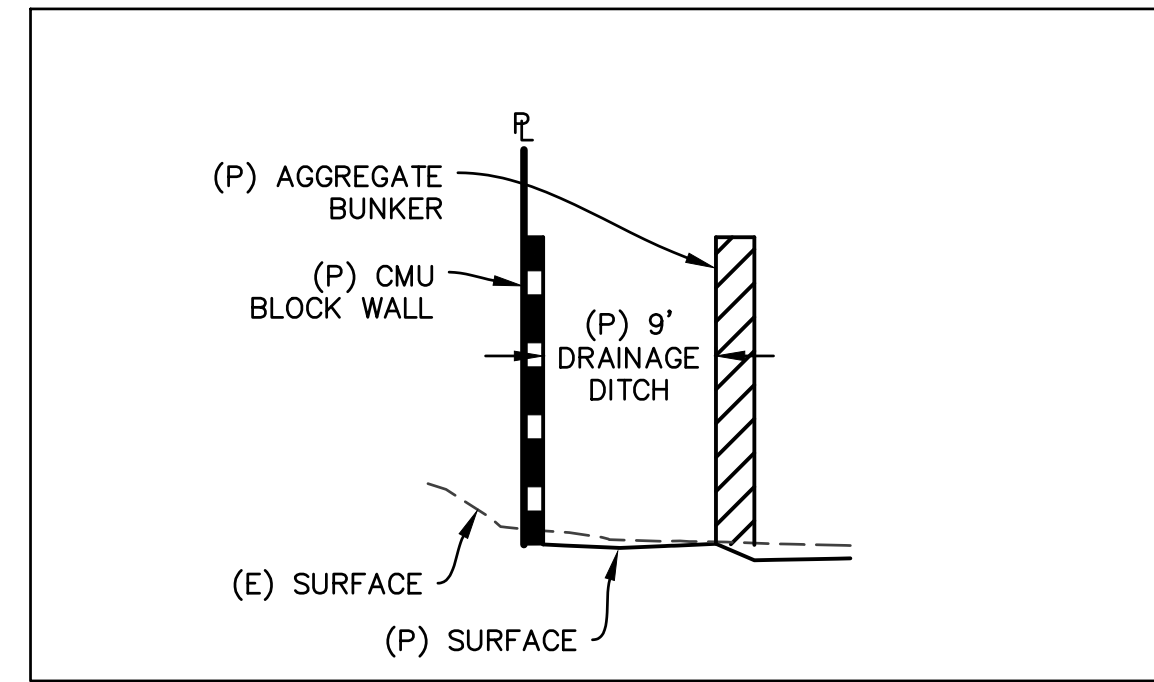

**SECTION B**  
HORIZONTAL SCALE: 1" = 10'  
VERTICAL SCALE: 1" = 5'

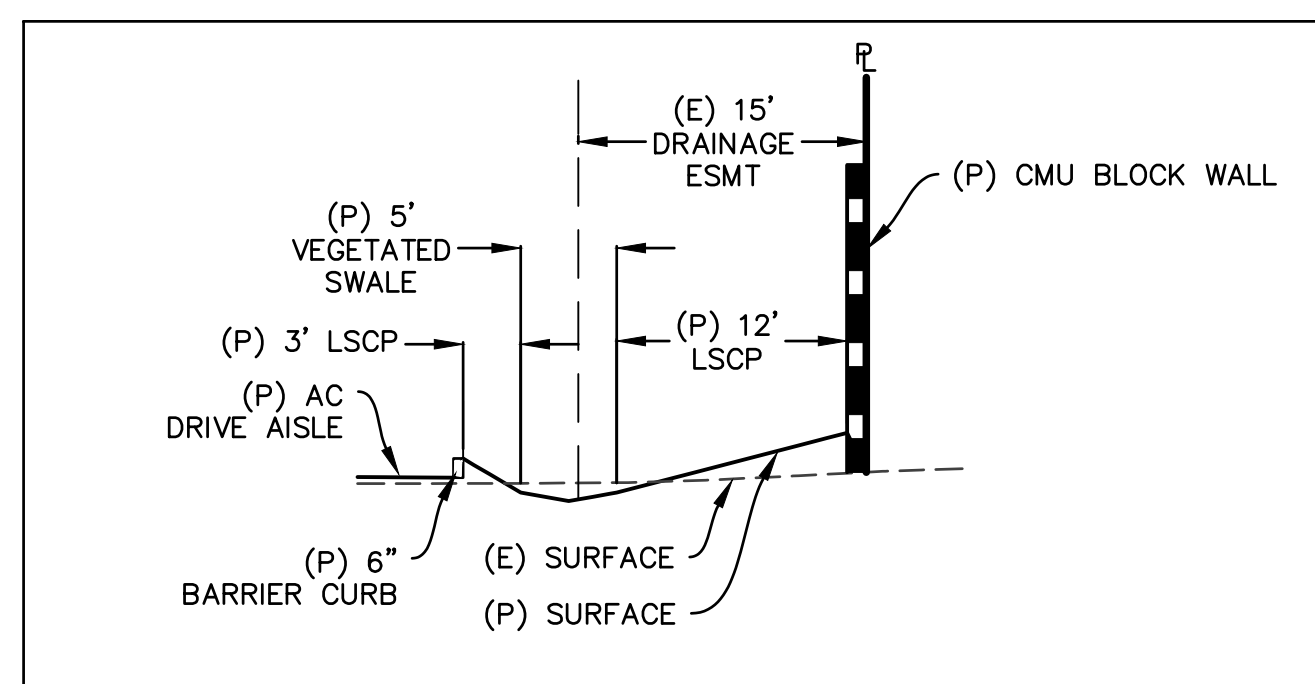

**SECTION C**  
HORIZONTAL SCALE: 1" = 10'  
VERTICAL SCALE: 1" = 5'

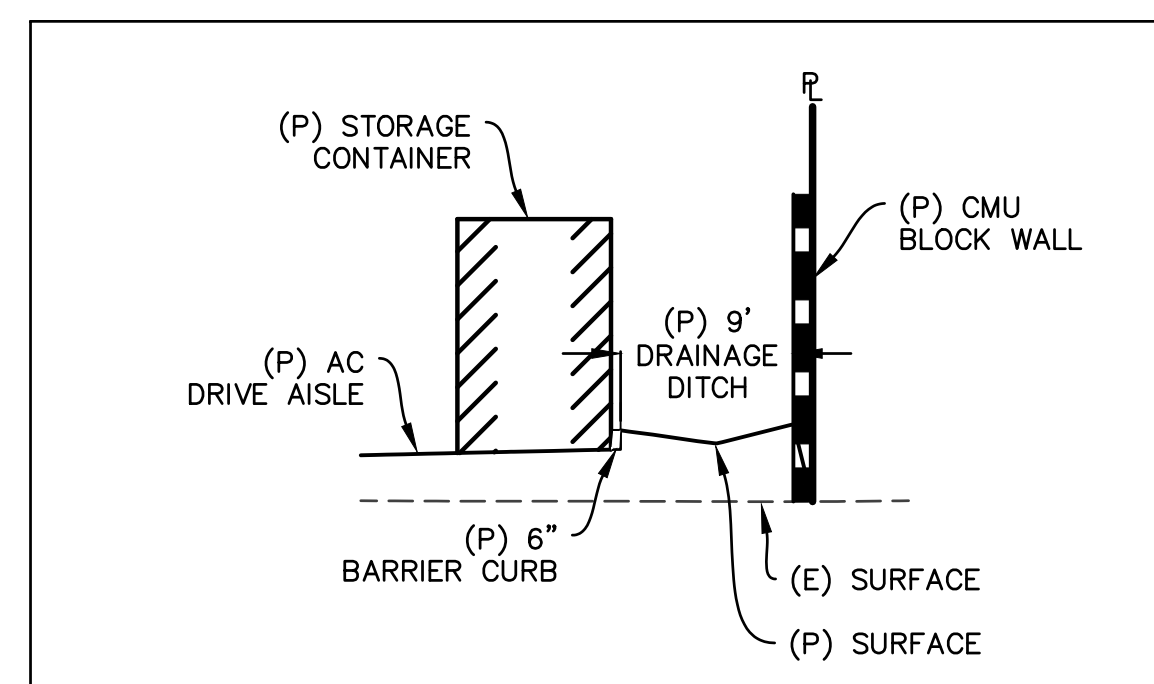

**SECTION D**  
HORIZONTAL SCALE: 1" = 10'  
VERTICAL SCALE: 1" = 5'

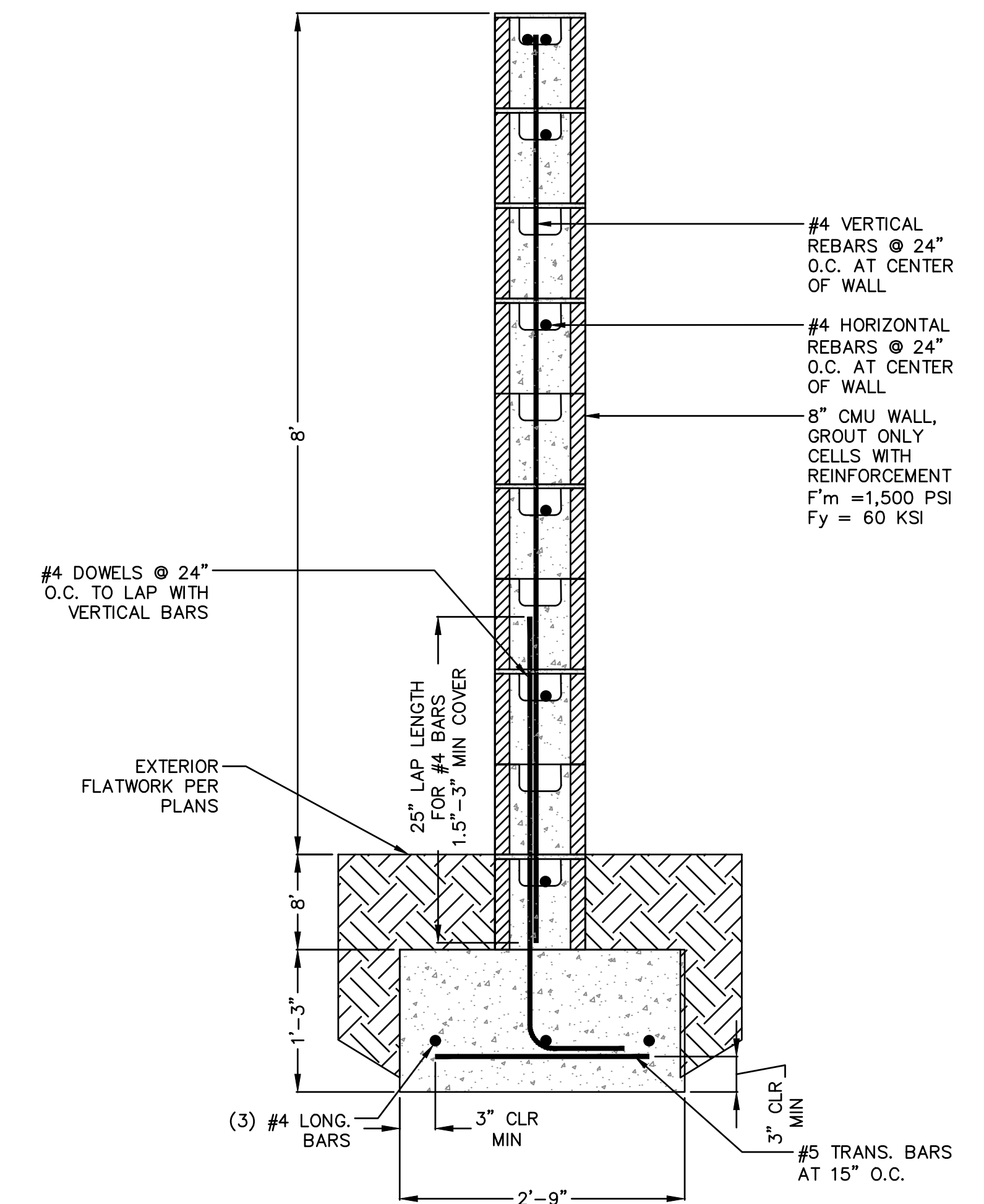

2 NTS CMU BLOCK WALL

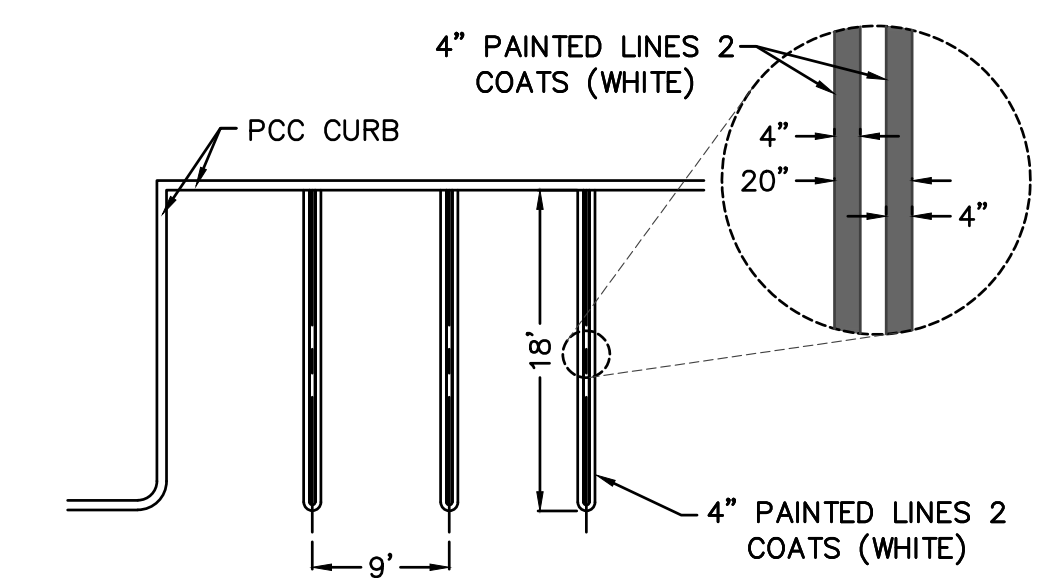

1 NTS PARKING STALL STRIPING

REVISION	DATE	BY	APPRVD
CHECK NO.			
BY	CHECK	NO.	
DESIGN	AEB	RFE	
DRAWN	AEB	RFE	
QUANT.			
0			
ORIGINAL SCALE IS IN INCHES			2
<p><b>ROSEVILLE LANDSCAPE MATERIAL</b> 1801 PFE ROAD ROSEVILLE, CA 95747 CONTACT: BALWINDER SINGH GILL PH: (916) 709-6619</p>			
<p><b>2021 LENDELL LANE</b> ROSEVILLE, CA 95747 APN: 473-100-045 <b>CONSTRUCTION</b> <b>DETAILS &amp; SECTIONS</b></p>			
Sheet			C6
6 of 6			
10/31/2025			

W:\2022 Projects\22-131-2021 Lendell Ln Roseville WORKING CAD\C6 CONSTRUCTION DETAILS.dwg Oct 31, 2025-04:15 pm